

Vertical Mill (GMV)

Efficient and Versatile Vertical Mill: High-Performance, Leak-Free, Durable, Hygienic

The Vertical Mill (GMV-series), constructed from high-grade steel, incorporates a mechanical seal type to ensure leak-free operation under various conditions, optimizing space utilization. It guarantees consistent, efficient processing, longevity, and minimal downtime.

This versatile machine effortlessly handles high and low viscosity mill bases, streamlining efficiency in one-tank operations. Its energy-optimized design reduces consumption, ensuring cost-effective performance. The Vertical Mill allows for smaller foot-print, and more efficient than horizontal mill.

The ability to use harder media increases its flexibility. The Vertical Mill represents a dependable and efficient milling solution.



Efficient Processing

Effectively grinds high-viscosity concentrates



Mechanical Seal

Ensures leak-proof operation and extended equipment life.



Versatile & Efficient

Handles High and Low Viscosity Mill Bases



Hygienic Design

Stainless Steel Tank & Pocketless Valve for Easy Cleaning.



Durable

Built for longevity and minimal downtime. High quality steel



Energy-Optimized

Low energy consumption for cost-effective operation



SCADA + HMI Control & Monitoring Option



Hygienic Design Option



Hazardous Environment Option

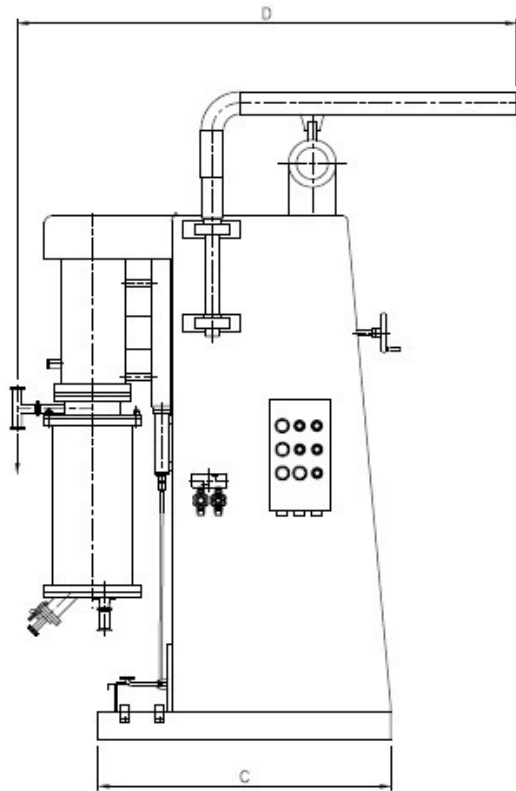
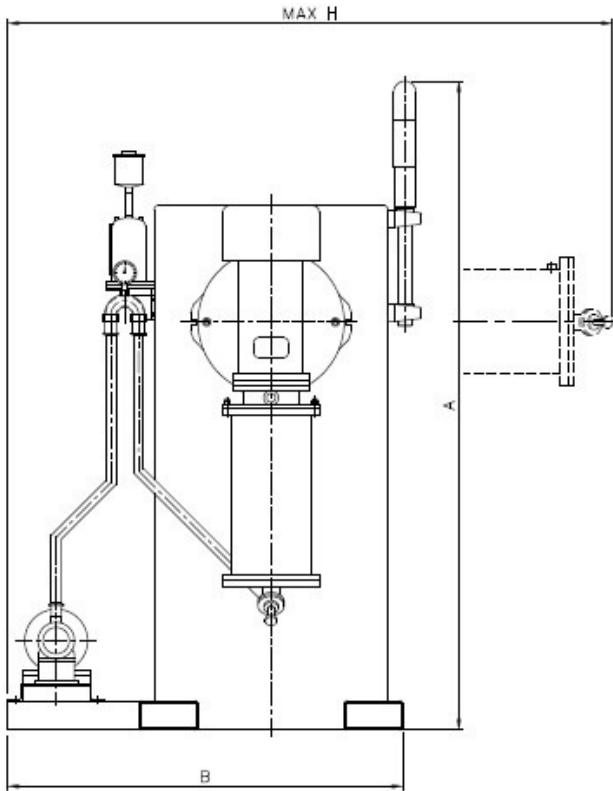

Model	Vessel Capacity (ℓ)	Motor (KW)		Peripheral Speed m / sec	Weight (kg)	A	B	C	D	H
		Main	Pump							
GMV-20MR	20	15	1.5	12	1200	2220	1350	1000	1677	2080
GMV-50MR	50	30	1.5	12	1500	2455	1450	1250	1734	2495



Cyclelect Nismix Pte. Ltd.

515 Yishun Industrial Park A, Singapore 768737
 T: +65 6868 6000 • E: hello@nismix.com.sg
 W: nismix.com.sg

70+ years of industrial powder and liquid mixer solutions, from concept to integration, empowering production plant owners.

